

THE ORGANIZING PRINCIPLES OF GURUNG KINSHIP

Victor S. Doherty

Madison, Wis.

The Gurungs are a people made up primarily of hardworking diversified farmers living in villages clustered on the slopes and hills around the Annapurna Himalaya range.¹ They are known to most other Nepalis as well as to the world at large primarily for the record of bravery of their men in the armies of Prithvi Narayan of Gorkha (who united Nepal in the eighteenth century), and later in the armies of Britain and India as well as of Nepal. In terms beyond these however the Gurungs are representative in the western hill areas of one of the main cultural traditions in Nepali civilization. As individuals and as a group they are making important contributions in the physical and social development of the country. It is important that cultural factors relating to these contributions be known.

This article is written as a first report from the field concerning the research on which it is based. I have been especially interested in the effects of culture on economic adaptation by the peoples living in the city of Pokhara in west central Nepal. In my work on this topic I have become convinced that kinship and marriage systems form perhaps the most important organizing forces in the adaptational situations I have studied.² Kin and marriage systems may be considered as flexible adaptive mechanisms which have grown up over years of social interaction and are able in a number of environments to provide important support to a society sharing in a particular tradition. From a different point of view they can be seen as expressive of persistent cultural ideals. In either case, it is found that kin and marriage systems promote

the organization of society according to distinct cultural rules. In my research in Pokhara I discovered, working with groups that are not "kin based" in the narrow sense, that this basic organizational importance of kinship principles holds true in a situation of change and modernization. Rules appear as guidelines and not as limitations: specific cultural content is seen to change, but it is seen to change according to a process of conscious or unconscious selection on the part of the individual in society. These rules seem to apply outside the kinship sphere in other areas of social life and action.

BACKGROUND TO THE EXAMINATION OF GURUNG KINSHIP:
SETTLEMENT, ECONOMIC CHOICE AND RUNNING A BUSINESS

An examination of the Gurung kinship system in this light should be preceded by a résumé of things observed in Gurung everyday society which seem to call for cultural explanation. It is not possible here to give a detailed discussion of all these circumstances. It is however possible to mention them briefly and to point out the main principles involved.

There are many Gurung villages in which from a majority of families at least one son or the husband is serving in the British, Indian, or Nepali armed forces. Several Gurung families I know in Pokhara have up to three sons presently serving, while their father is retired on pension from the same service. The monetary incentive to such service is certainly strong, for after serving the required number of years one can be assured of a not inconsiderable pension paying often from one to several hundred rupees per month for life. If a man is killed in service his widow collects the pension. Economic necessity plays a great part in this orientation to military enlistment, for hill agriculture in Nepal is increasingly an occupation of small return for great

labor. But if the monetary inducement is strong, still the fact of the Gurungs' apparent ready adaptation to army life does seem to require explanation. A need to make money outside farming, and a desire to see the world, cannot account completely for this adaptation. Brahmin and Chetri men and boys of similar economic and educational background leave the village to seek experience and earnings outside Nepal, but their search usually leads not to the army but to jobs as guards or hotel and teashop waiters in India--jobs in which the pay is poorer, the work more menial if less dangerous, and there is usually no possibility of a pension. Some people explain all this by the statement that the foreign armed forces simply have a policy of recruiting primarily Magars, Gurungs, Rais, and Limbus. But this statement does not explain how such a policy could have come to be instituted. To fall back on an "explanation" which invokes the warlike effectiveness of the "martial tribes" is to use the tired words of the last century while making no explanation at all.

One also finds situations in modern-day Pokhara which seem to require a more-than-circumstantial explanation. Pokhara is a town of high land values and high prices: high prices resulting in the end from the inflation affecting all of Asia; and high land values arising from the relative scarcity of good arable land outside the town, along with the high value placed on bazaar plots because of the town's importance as a trade center. Because of these things, although there is a good deal of immigration at present the majority of Gurung immigrants are those with some amount of extra resources behind them, or else those with special skills (often gained in the army) such as driving or automobile and truck repair. What is interesting is the contrast between Brahmin-Chetri and Gurung response to the challenges and opportunities offered by Pokhara. Among Gurungs there has been much immigration from villages up to two or more

days' walk distant, which means that most of the Gurung hill settlement areas³ are involved. There has been relatively little Brahmin-Chetri immigration to Pokhara; even when wealthy these people seem to stay put as long as possible, and to move when it becomes necessary to Chitwan or to other Terai areas where land is available. It can be stated as a Brahmin-Chetri characteristic that most prefer to live on their own farming land, or at least to be quite close to this. Gurungs have moved into town in great numbers, leaving their home fields in the care of relatives or of sharecroppers. In the past five years especially, a period which I have been able to observe personally on visits to Pokhara and in a year's intensive research, the influx has been very great.

While Gurungs have settled where they can--that is, where land and building space are available--as a group they seem to have a different interpretation than do the Brahmin-Chetris of what is "possible" for them as a settlement area. At present they have established themselves in three main areas; in the north, east, and south of the present City Panchayat area. Gurung settlement in all of these areas is dense, whether the spot in question was or was not a nucleated bazaar area when immigration began. A detailed census in one of these neighborhoods reveals a number of Gurung families which is surprising even to a Gurung resident of the area. The comparison between this residential pattern and that of the Brahmin-Chetris, who are also participating in the modernization of Pokhara but who generally live on widely-spaced homesteads in the outskirts of the town, is exact when it is drawn along with the variation in type of these groups' rural settlements. In the rural areas a Brahmin-Chetri village is most often just a general settlement region, with little nucleation and with scattered houses. A Gurung village is tightly packed, whether or not it occurs in an area similar ecologically to those of most

Brahmin-Chetri settlements. In rough terms, a Brahmin-Chetri village grows by spreading. A Gurung village grows in the hiving-off and subsequent multiplication in one place of a few founding families, whether these establish themselves on land contiguous with the old nucleated area or in a new village settlement area. One can find an example of this latter situation in a large Gurung village on the western border of Lamjung District.

The village in question is very large and closely-packed. It lies midway on the mountainside between the ridge forest and the river, and is surrounded by its fields. Separated by a slight ridge running down the hillside, and lying half an hour's to an hour's walk away, are the northern fields. There are now no buildings in these fields except for a few cattlesheds which are never inhabited by any of the villagers except temporarily. But it is not hard to visualize the next steps: a few families will decide to build and live there, and a new village will be born as their children grow up and build next to their parents. The rural pattern seems to fit the urban pattern, and in the case of the Gurungs in Pokhara this is definitely so. The process of creating new settlement areas has not yet passed the first generation in the town. Still, the old pattern is seen in the new settlements in Pokhara. These are nucleated and draw their settlers each from a distinct circle of hill villages which form a common hinterland to one or another bazaar neighborhood.

There is also the matter of making a living in town. Almost all the Gurung businessmen I have canvassed--in a sample of about seventy individual families living in Pokhara--have connections with the land. In this they certainly agree with the Brahmin-Chetris, and with most if not all other groups in Nepal. It is the only practical course in an agricultural country. Their

supplementary occupations however (and these are their major occupations in the bazaar) differ radically from those of Pokhara's Brahmin-Chetris.

The differences come partly in the nature of the businesses which Gurungs begin and partly in their manner of running them. They are present in important or predominant numbers in taxi owning and driving, bus companies (two out of the three Pokhara-owned companies), motor repair, etc. All these are skills learned in the army; that they should predominate in these fields thus seems natural. They are not alone in these fields of enterprise; members of other ethnic groups represented in Pokhara participate, and Brahmin-Chetris are beginning to move into transportation. What seems unique is the higher percentage of cooperative enterprises among Gurung businessmen. Whether one is speaking of buses, hotels, or finance one finds groups of Gurungs--groups made up of relatives, friends, army associates, etc.--involved in the active, cooperative day-to-day running of the business. Where partnership is involved among Brahmin-Chetris it is often a case of financial investment, not active partnership. Brahmin-Chetris show a distinct preference for one-man businesses, and while a few Brahmin-Chetri families in the area have been involved in business off and on for several hundred years these enterprises also have been one-man affairs.

The institution of dhikuti (or dhikur; see Messerschmidt 1972) is another case in point. As a business means this method of setting up ad hoc, cooperative credit associations was first established in Pokhara by the Thakalis. Brahmin-Chetri businessmen speak of the system with a good deal of respect, in these terms: "Even a poor Thakali can become rich. If a Thakali comes to town and wants to set up a business but has no capital and nothing to mortgage the

other Thakalis get together and loan him what he needs to begin. Then he pays this back to them later on." This is a very incomplete conception of the actual process of dhikuti. I have never encountered such comments among Gurungs, who recognize the Thakalis' solidarity but are more understanding of the way in which this solidarity is manifested. Many Brahmin-Chetris who do know and understand the dhikuti rules however stick simply to comment on the effects of the system and phrase their comments in the way quoted above; as a group, they are not concerned with joining in.

The actual process of dhikuti is as follows. If a man (or woman, although women most often organize a dhikuti with other women only) is judged trustworthy he can initiate or be invited to join with others in a cooperative credit association. It is often required that each member have a jamāni or guarantor committed to step in and fill his place if he defaults or cannot continue for some reason. Members varying in number from 5 to over 20 put down perhaps 75 or 100 (or more) rupees each, and the man most in need of it will take the entire amount. He can then start a shop, build a house for rental purposes, buy a taxi or set up in business in any other way which will give him a guaranteed income and for which he could not have raised the extra capital otherwise. The others then take their turns which can be determined by request, bidding, lot, or a combination of these. An agreed-upon rate of interest is added to the basic amount at each subsequent payment date, by each "player"⁴. Messerschmidt (1972) calls this "increment"; a flat percentage of the initial amount is added once at the second payment, twice at the third, and so on. Thus, adding 10% each time for example, payments based on an initial amount of Rs. 100 would run as Rs. 100, Rs. 110, Rs. 120 and so on, deposited

beginning with the first meeting. Persons coming to their turn after the initial meeting receive the interest payments also, as compensation for taking a later turn. Interest at, say, 10% can mean that the initial and other early "players" pay a good deal over the full course of the dhikuti contract. This is offset by their having been able to raise money and start a business easily and quickly only through relying on people they know.

The interesting thing about dhikuti is that in terms of those who "play" it is primarily a Thakali, Gurung and Newari phenomenon. Membership is not limited by formal or informal ethnic considerations; Brahmin-Chetris "play" but relatively many fewer of these people are involved. Brahmin-Chetri comments run to dwelling on the "uncertainty" involved in dhikuti. They would always be worried, they say, by the insoluble trouble which might arise if a member defected or defaulted. Gurungs on the other hand simply regard dhikuti as one among many money-raising possibilities. The presence of jamānis, if the dhikuti is organized to include guarantors, is considered enough security. In my own experience those who are not interested are often those who have the resources in any case to get a bank loan at cheap rates; or they are among those who arrived in Pokhara with savings, land-sale, or land-income funds sufficient to support their initial enterprises. Several Gurungs who expressed little interest in dhikuti nevertheless fit the pattern in that they are extensively involved in cooperatively-run businesses.

COMMON PRINCIPLES IN GURUNG ADAPTATION TO A NEW MILIEU

In the facts of Gurung adaptation to a new milieu patterns emerge. There is a willingness to work formally in concert, whether with friends or with family. There is also a preference for life with a group, rather than

for settling down on a physically separated plot or homestead.⁵ The pattern overall is egalitarian; egalitarian traits are among the strongest and most striking in Gurung society. In this context, the nature of Gurung internal status divisions is instructive. Beyond individual and family concerns with general economic and social status achievement and retention (such concerns are of course found in the members of almost all societies) the Gurungs are divided internally into the cārjāt and the sorajāt or the Four Clans and the Sixteen Clans⁶. The two groups are traditionally endogamous, and the Four Clans have higher status in a village context. But status differentiation for Gurungs never reaches the overall cultural importance and complexity it reaches among Brahmin-Chetris. The Four Clan/Sixteen Clan division, as a matter of principle, is little discussed with others by Gurungs. It seems to be felt that an outsider could incorrectly assume Gurung society to have "caste" divisions. In fact the Nepali word jāt, applied to Gurungs in a conversation carried on with them in Nepali, always carries a somewhat wrong connotation. The Gurung language uses mai "people" where Nepali jāt would be used. The clans seem to be little different as groups than the old Scots clans (MacGregor, MacLeod, etc.); in Scotland too of course some clans were in power and some were not.

Cultural bases for these egalitarian and group-oriented principles of social organization can be seen quite clearly in an examination of the Gurung marriage and kinship system.

GURUNG KINSHIP: THE MARRIAGE RULES AND THEIR SOCIAL CONSEQUENCES

Gurung ideas on marriage are based in one of the major general traditions in west central Nepal. Main features of their marriage system, and some

of the kin terminology, are shared by their near neighbors the Thakalis. Although my own exact information is incomplete, most of my informants' say the Manang-gi tradition is in agreement with that of the Gurungs. Rules affecting marriage differ for the Magars (see Hitchcock 1966); but as Magar informants explained their traditional funeral customs to me an attitude similar to the Gurungs', of interdependence and of son-in-law's responsibilities, was revealed.

The Gurungs are a patrilineal people. The key to the system for arrangements of marriage among these patrilineages lies in cross-cousin marriage, and in the rules and interpretations made by the Gurungs concerning such marriage. Either cross-cousin--mother's brother's or father's sister's child--is a possible marriage partner. These persons are called by the same terms: ngoh lõh (male) and ngoh lo syo (female).⁷ Father's sister's daughter marriage has priority. The traditional or village rule, stated in the same terms by all of my older informants and confirmed by young people, is this: "Until a man is married, or until he waives his right to her, he will have first call in marriage for his father's sister's daughter." As I have said, I encountered this rule continually. Pignède's (1966: 228 i.a.) statement that for Gurungs there is no traditional rule of preference for one or the other cross-cousin must be rejected. Informants from the entire range of the Gurung territory have phrased the traditional rule as I have quoted it above.⁸

The clearest explanation of the Gurung conception of this kind of marriage came from a man, a native of Parbat District, whom I asked to explain Gurung marriage rules. His first statement on the subject of marriage concerned father's sister's daughter marriage, for which he drew the following diagram:

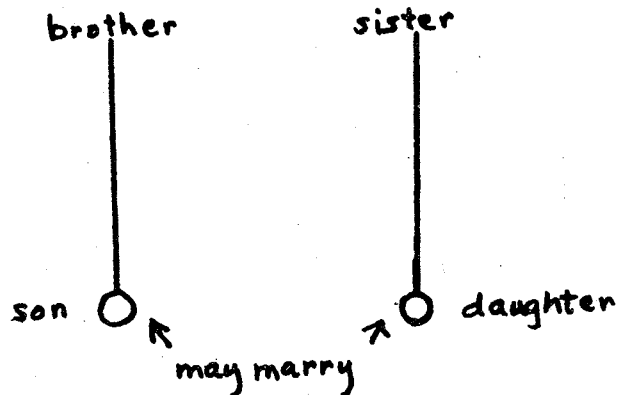

Diagram 1: an informant's diagram of the traditional Gurung marriage rule

It should be noted that this diagram can only be interpreted to show FaSiDa marriage. According to another informant, FaSiDa (or MoBroSo, which is the same relationship from the woman's point of view) marriage is considered suitable since bride and groom are born "of seed from men of different families". A young Gurung man stated that there is a very easy relationship between a man and his father's sister she is solicitous for one's welfare, and there is the expectation that her daughter will be given if requested when the time comes to marry. The relation is that of mother-in-law and son-in-law to be, reinforced by the brother-sister ties in the elder generation.

Robin Fox (1967: 204-207), in his book making use of many of the interpretations suggested earlier by Lévi-Strauss, provides a diagram charting the movement of women under such a marriage regime. It is one in which the direction is reversed in each successive generation:

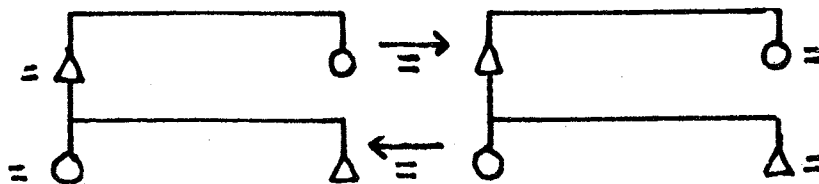

Diagram 2: FaSiDa marriage (adapted from Fox, 1967)

According to Fox a system of preference for the FaSiDa is relatively rare but nevertheless closely connected with certain types of society: those which are, in his words, "egalitarian but competitive". For such societies status is important but it must not become too unbalanced, whether in favor of an individual or a lineage. Egalitarianism is the rule, and all other things being equal a gift (or a bride) given requires a return. I found these principles to be true for the Gurungs in general; they seek close social contact, give and receive hospitality freely, and generally seek to establish relations best described as of mutual respect. The result of the primary rule concerning marriage is that no one lineage will be at a permanent disadvantage in terms of the status differential established by marriage, unless there is a decision made on other grounds to waive the right to a FaSiDa marriage.

At this point it should be noted that for Gurungs (and for the Thakalis, the Nagars, and the Manang-gis also) the line which provides a woman in marriage ranks higher than the line which accepts a bride, as the status effects of the marriage itself are reckoned. It is only the Brahmin-Chetris in this area who consider the accepting lineage to rank higher as a result of the marriage.

Despite the unambiguous phrasing of the Gurung marriage rule, there may be some disagreement as to its correspondence with other aspects of the Gurung kin and marriage systems. Pignède (1966: 228), who did much of his research in Parbat District, states that a Gurung "usually will choose his cross-cousin on the maternal side" if he does make a cross-cousin marriage. Statistically in the marriages he recorded in one village, he found a somewhat greater prevalence of MoBroDa marriage. Kin terminology I collected from the beginning of the eastern part of the Gurung territory, on the Kaski-Lamjung

border, shows nearly identical terms for FaSi or MoBroWi on the one hand, and MoBro or FaSiHu on the other. This situation in itself could be taken as pointing at least to an earlier rule of sister-exchange marriage.

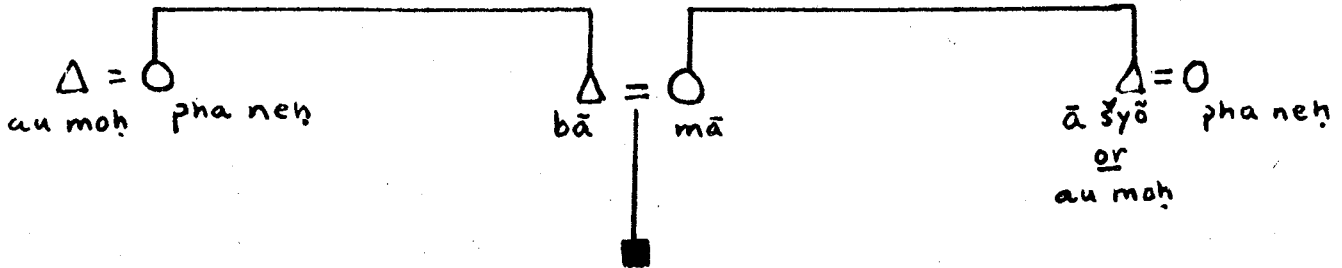

Diagram 3: eastern area cross-uncle and -aunt terms

But these terms are not replicated exactly in the western area, where there is variation in the matrilateral terms:

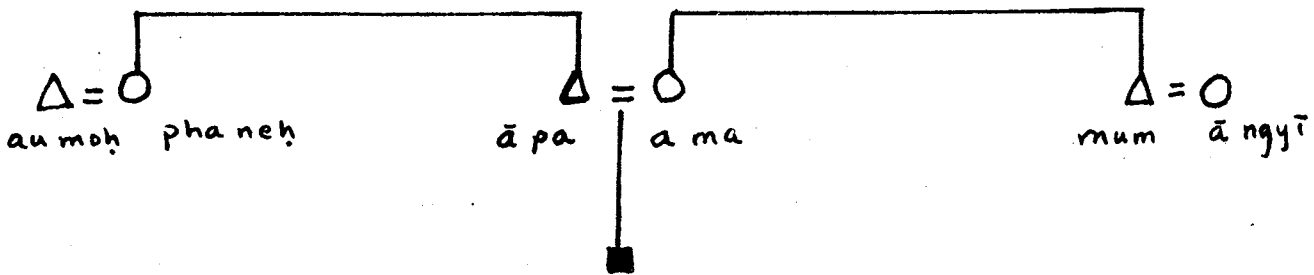

Diagram 4: western area cross-uncle and -aunt terms

Linguistically, the WGrG term mum for MoBro seems to be derived from the Nepali māmā "mother's brother". The western-region ā ngyi for MoBroWi seems to be a Gurung term most easily translated as "respected elder woman".

But the close correspondence between the patrilineal and matrilineal terms used in the eastern region seems to call for more than an explanation suggesting greater linguistic conservatism there. One could assume on looking at the eastern terms, and on correlating their virtual identity with the identity of the cross-cousin terms used in both dialects, that sister-exchange marriage is or very recently was the Gurung rule.

Such a conclusion would have further support, from other rules affecting marriage. As already mentioned, the Gurungs are divided into two status groups of the Four Clans and the Sixteen Clans. Among the Four Clans in some areas there is assumed to be a "brother" (Nepali dājū-bhāi) relationship between the Ghale and Ghotane clans on the one hand and the Lāmā and Lāmchāne clans on the other.⁹ If one were to hazard an attempt at historical reconstruction on the basis of the information presented so far it might go along these lines: that the Four Clans were the first to arrive on the scene, and the Sixteen Clans represent later immigration at disconnected periods; that the Four Clans, through population expansion and migration, became scattered and subsequently split into four groups from what were anciently two patrilineal lines regularly practicing sister-exchange marriage; that the common origins in two groups were remembered among members of the Four Clans, so that marriage was forbidden between the segments Ghale-Ghotane on the one hand and Lāmā-Lāmchāne on the other.

In fact there is no basis for such assumptions. Not only informants' statements but a closer examination of the terminology leave father's sister's daughter marriage as the primary rule to be explained in cultural terms relating to social organization. A closer examination will also show that there is no reason to separate the Four Clans from the Sixteen Clans on any major cultural basis or in any proposal of a migration time-frame. The difference of these

two sub-groups in particular is only one of general social status in a village context, and even this difference is not hard-and-fast or of primary importance.

All this becomes clear when the dynamics of marriage are considered and when the relevant kin terminology is examined in detail. To consider the terminology first: except for the terms for MoBro and MoBroWi in the western area, where my informants agree that some do and some do not observe the supposed brother relations for Lāmā-Lāmchāne, Ghale-Ghotane within the Four Clans, there is complete agreement in terminology for the following relatives:

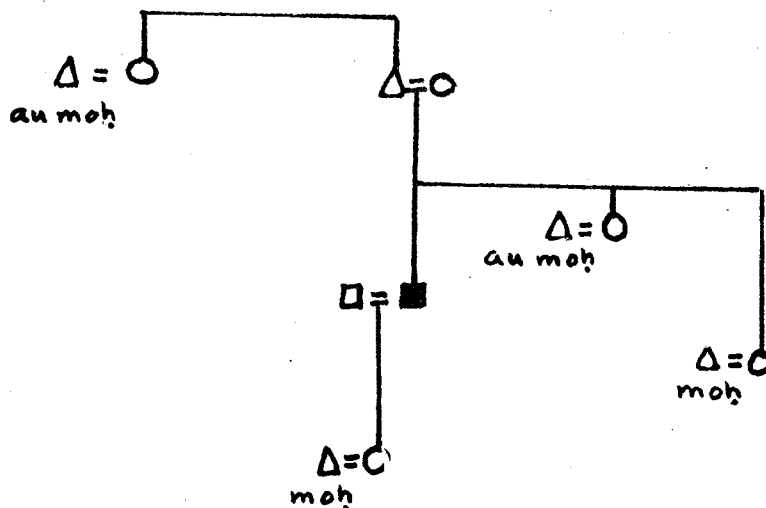
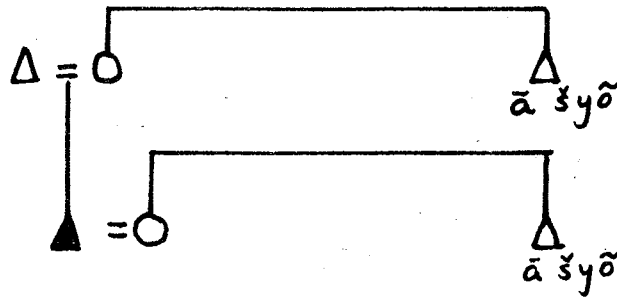

Diagram 5: male affinal relatives

From this context it becomes clear that moh, with the honorific au moh for a person elder than one's self (i.e., elder in generation or married to an elder sister) is a basic term meaning roughly "one who has married a woman of my clan". It is an affinal and not a consanguineal term. We have already seen that a possible eastern term for MoBro is ā syō. It is also a possible term for WiEBro in either dialect:

Diagram 6: reference of ā šyō

One of my informants described what he called a "style" of the moment in his family: the people of his elder brother's wife are called, collectively, ā šyō mai by his mother. It seems clear that ā šyō also is basically an affinal term; its meaning is "person (especially male) of a clan which gave us a woman in marriage". Furthermore, the term ā šyō is actually little used outside a ritual context. One's ā šyō relatives are especially important at funerals and memorial or argon services (see Pignède 1966: chap. XII). In these cases there is a definite pattern which ritual gifts must follow. The deceased's ā šyō gives to the deceased, and this gift is claimed by the deceased's moḥ or son-in-law; the gifts parallel the movement of women in marriage which occurred in life.

In the light of this discussion on the terms au moḥ and ā šyō it becomes easy to see why there is correspondence between the terms for cross-uncle and -aunt and their spouses in the eastern dialectal region. The area from which I collected these terms is one which maintains brother relations between groups in the Four Clans, and my informant was a member of one of the Four Clans. It is a basic rule in Gurung society, followed strictly in the village and to a large degree in the city, that one does not address a person--especially a person of an elder generation--by his name but rather by a title or by a kin term. When one must address a fellow member of the Four Clans by a kin term in the

eastern dialectal area the possibilities are neatly limited. If one is of the Lamchane clan then not only other Lamchanes but also Lamas will have a patrilateral term. And whether a Ghotane or Ghale man of the preceding generation is one's mother's own brother or not he is accorded an "elder brother" or "younger brother" term by her. One then would call this man au moh if in the context one wished to stress that he can only have married a woman one classifies as "father's sister", or he could be called ā syō if the stress were to be laid on his brother relation to one's mother. The man from whom I collected this example of the eastern terminology seemed to have a preference for the use of au moh in this situation. This term of course emphasized Ego's own lineage's somewhat higher status in the marriage alliance framework.

With the addition of one more consideration, it seems possible now to suggest a more likely origin for the custom of observing fictitious kinship between certain Four Clan groups. This custom probably arose as a means of binding together more closely groups which were in power during the very long period in Nepal's history when the village headman administration system was in effect. The actual origin may have been simply a mit (Grg ngyeh lōh) ritual brotherhood alliance between the leaders of groups in power. Traditionally, these groups were the Four Clans. The mit relation is very important throughout Nepal and is today very often contracted between individuals. Men establish a mit relationship with other men, women with other women. An alliance beyond ordinary friendship is formalized in this way to promote smooth social relations. If such relations were in fact contracted at some earlier time among members of what are now called the Four Clans, this in itself would account for the terminological and marriage-rule problems I have been discussing. A mit uses consanguineal kin terms for the entire family of his ritual relative,

and members of the two families cannot marry.¹⁰

The discussion on Gurung marriage rules can best be closed with a specific illustrative case. In recording the genealogy of a woman from Parbat District, we came to a point at which the informant stopped me and said, "Here, this is a perfect page to show our marriage system: just like a barter system!" The section in question shows the marriages arranged by their parents for a girl and her two brothers. One brother was married to his mother's brother's daughter. The part which struck my informant as typical and caused the exclamation was this: the remaining brother married his father's sister's daughter; his sister married her mother's brother's son. Each of these latter marriages is a father's sister's daughter marriage analytically. The effect of these latter marriages was an exchange of brides between two patrilineages linked by marriage in the preceding generation, an exchange which repaid the social debt in each direction.

In this case, which my informant singled out as especially illustrative, we have a demonstration of the two main principles in the traditional Gurung marriage system. One, the most important and that mentioned at the beginning of this section, is the preference for patrilateral cross-cousin marriage. Terminologically we can note that despite dialectal differences there is exact agreement on affinal terms. These are the most important in noting present and past marriage relations, and in noting the possibility of marriage in the future. The second principle is a corollary of the main marriage rule: it is that egalitarian relations are to be preferred and sought out. The egalitarian

nature of the overall system is to be seen in the main rule and is implied terminologically in the own-generation terms ngoh lōh / ngoh lo ŷyo applied to all cross-cousins. The implication is that if a marriage is arranged in one direction it can be arranged in the other also.

GURUNG KINSHIP: THE TERMINOLOGY

A central aspect of the Gurung kinship system is age and generational ranking. The importance of this is evident in social organization in both village and town life. Pignède's account gives an excellent idea of the importance attached to membership in an age group. Groups of young people (huri; Pignède has nogar but I have not encountered this term) exchange work between villages and provide a very important concentrated labor force during peak agricultural periods. In my experience young people as well as old, in both village and town situations, seek out and lay great stress on relative age. Kin links are traced carefully, and both near and classificatory links once established have a great deal of effect on behavior.

Age and generational order are central to the Gurungs' own conception of their kin system. Several informants stressed the basic importance of generational grading, with the eldest commanding most respect. In most situations I have observed that it is persons of the elder generation--in the village or in the town--who are the most careful to trace kin relations on meeting, so that their juniors must address them with the correct near or classificatory term.

Within one's own generation relative age alone is important. This is established, traditionally, by determination of one's lo barga or year of birth according to the Gurung adaptation of the Tibetan twelve year cycle.¹¹ Actual

relative age reckoned by whatever system is of course the most important in day-to-day social relations and among friends. But for family members and any relatively close kin it was stressed to me that "reckoning is by relationship, not by age" (sāino bāṭa ganča, umer bāṭa hoina). The man who provided Diagram 1 above also provided the following diagram in Nepali:

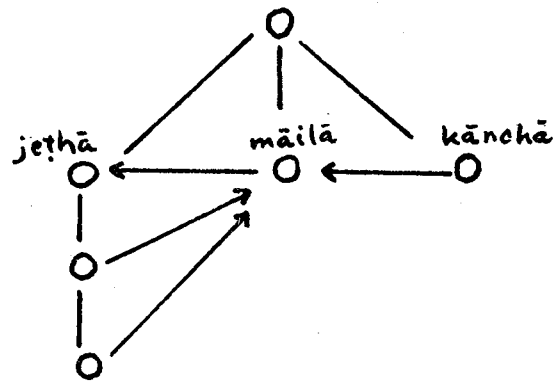

Diagram 7: kin-determined generational respect relations

The diagram shows a man, his three sons, and the son and grandson of the eldest. My informant emphasized that within the same generation (for example that of the three sons here) ranking follows age with the eldest ranked highest. After this, it is a matter of kin links. The man's second and third sons (māilā, kānchā) depicted here can easily happen to be born while their father is in his sixties, as the sons of a second wife for example. If the eldest son happened to have been born many years earlier it could happen that the eldest's grandson would be several years older than the middle son in the diagram. Still the grandson of the eldest must respect his grandfather's brothers, and must call them "grandfather" whatever their actual age. This rule holds in all similar situations where a fairly close actual kin link is traced. More generally an appropriate kin term based on age and social interaction is used, as a

respectful term of address and reference.

Age ranking and generational ranking are found in Brahmin-Chetri custom and in the customs of all groups in Nepal as far as I am aware. But the Gurungs especially place consistently strong emphasis on the importance of generational affiliation. In my observation too it is the Gurungs who base much of their day-to-day interaction on a large group of generational fellows, and who uniformly stress respectful relations with the elder generation. There are individual differences of course, and a concomitant of this emphasis on inter-generational respect is wide latitude for personal and group autonomy. On the whole, however, these rules result in an observable contrast in social relations. Among the Brahmin-Chetris for example social life is much more diffuse and more observant of particular status relationships, which can cut across generational lines.

The overall Gurung rule seems to be this: in general, status comes with age. Because of this there is relatively less concern with establishing individual status absolutely, vis-a-vis all persons of whatever age; there is relatively more emphasis on smooth relations with members of one's own age group. Vis-a-vis the members of this group there is a place and a demand for individual and leadership accomplishment. But the basic egalitarian principle is there, and relations within this group ideally must be mutually supportive. Status will increase with increasing age, but one's generational fellows will always be sharers in this status.

In the kin terminology itself there are some areas in which age-order is particularly elaborated. These areas are 1) FaSi, 2) own generation, and 3) children's generation. Except for minor phonetic variation the terms for

FaSi are the same in both dialects, as follows (western terms given):

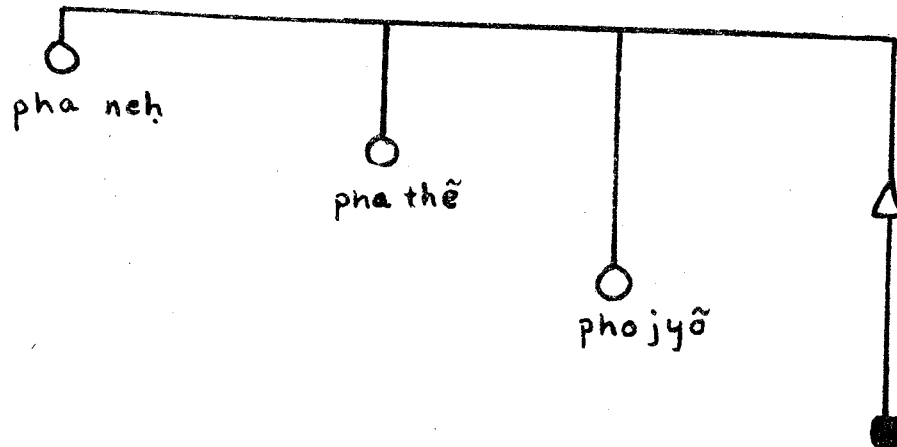

Diagram 8: FaSi terms, WGrG

This elaboration of terminology may be related to the importance of FaSi in the marriage system. Terms for other relatives in one's parents' generation are graded by age in the following uniform way (again, western terms given):

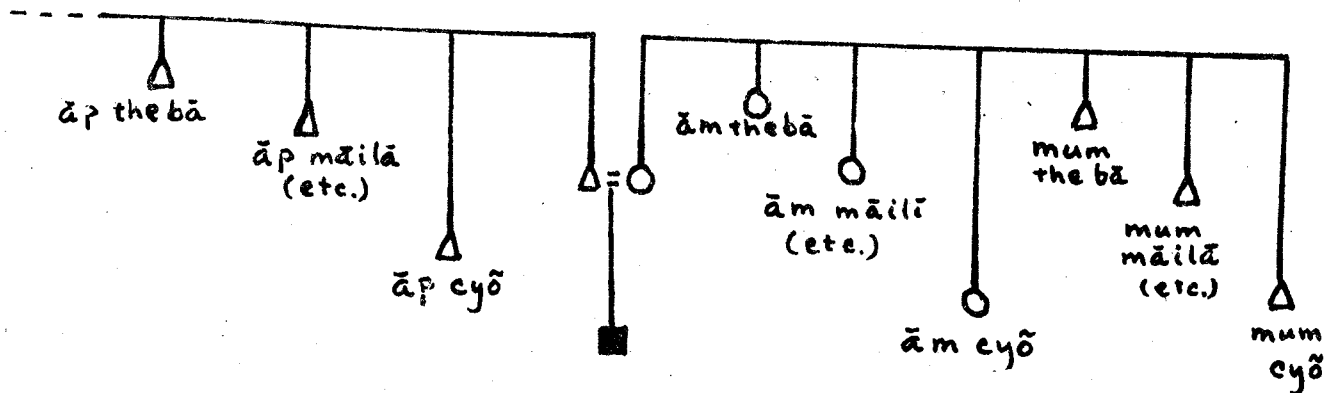

Diagram 9: parents' generation terms, WGrG

In one's own generation the terms are as follows, for siblings and for parallel cousins:

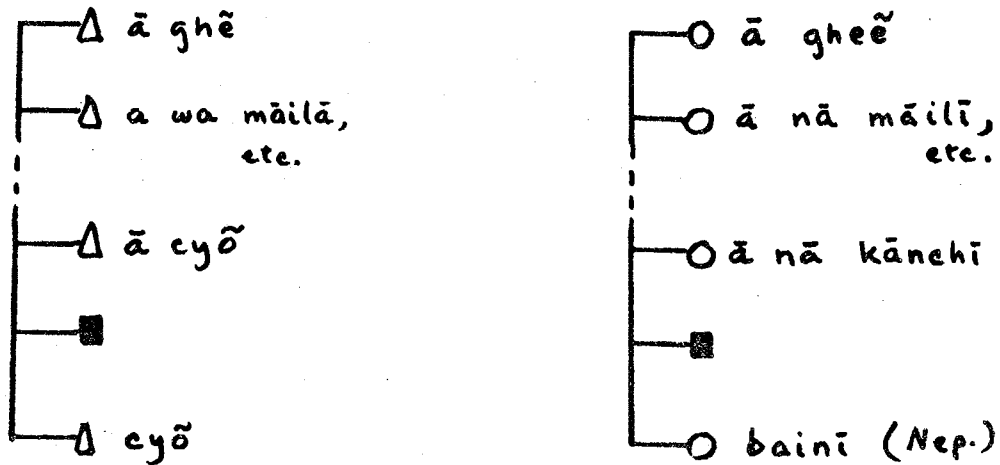

Diagram 10: sibling terms, WGrG

The only non-phonetic difference between this table and the usages Pignède gives is for ā cyō, which Pignède (1966: 279) says can be applied only to a youngest parallel cousin; I have personally observed the use given here. The terms for one's children's generation are as follows, for male Ego and then for female Ego:

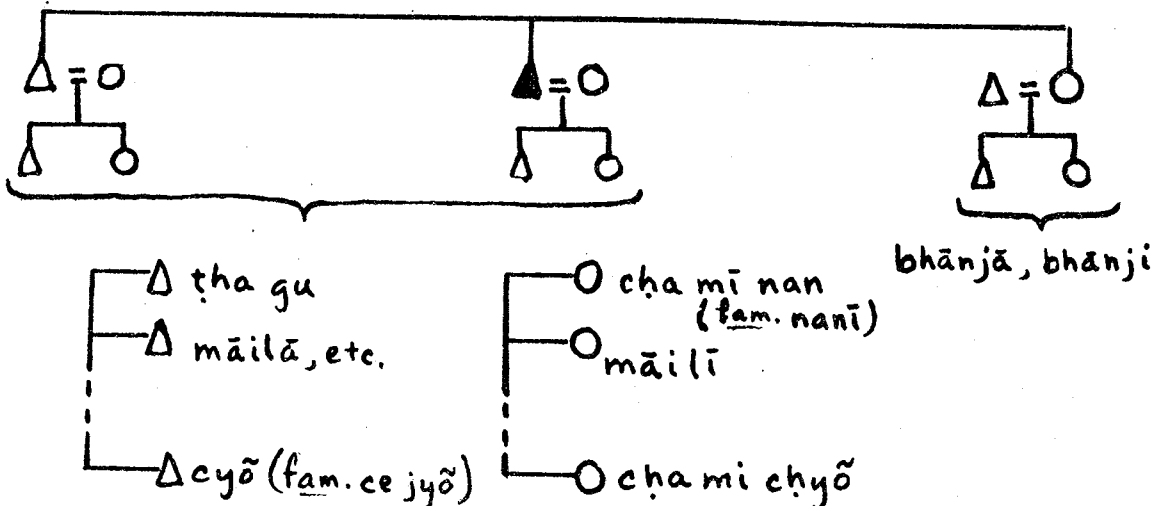

Diagram 11: children's generation terms, WGrG, male Ego

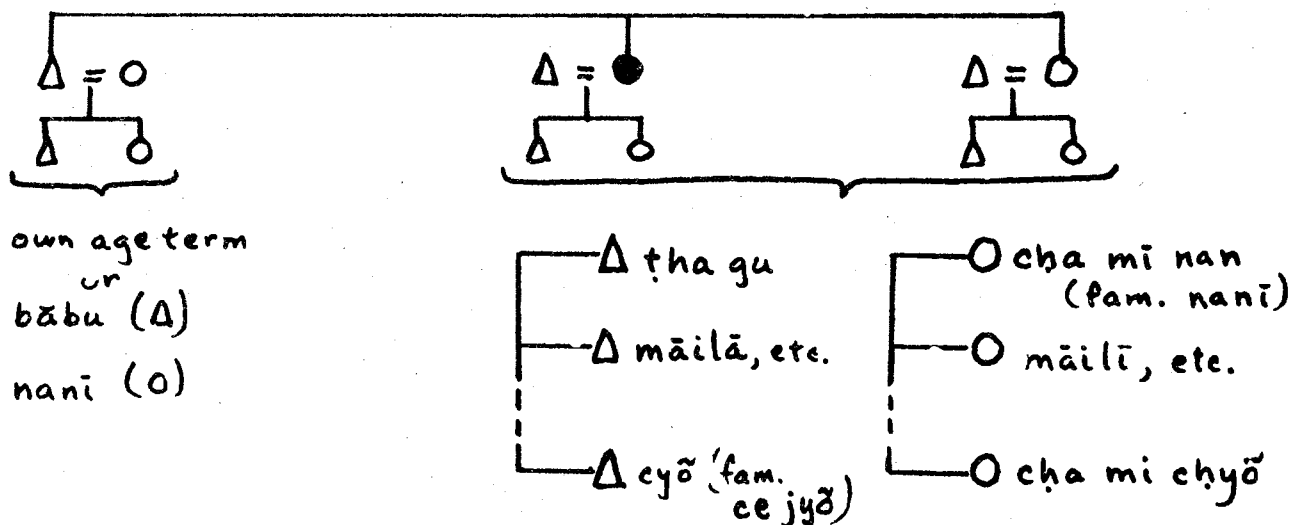

Diagram 12: children's generation terms, WGrG, female Ego

Children of cross-cousins are called by the terms for parallel offspring, depending on which parallel relative a cross-cousin would marry. Cross-cousins themselves are all called by the same terms mentioned earlier, and are not given an age term in the kin terminology.

There is as stated earlier emphasis on addressing another person by a kin term or title, even if the kin term used is fictitious in application. The Gurungs are not alone in having this rule; it is a general characteristic in Nepal. But the social interaction implied by these terms so used can be very different, depending on the ethnic group involved. During my study in Pokhara I found that linguistically there is progressively more and more influence by Nepali on Gurung kin terminology. Nepali is spoken often by Gurungs in Pokhara, even when a speaker knows Gurung and is conversing with other Gurungs who also speak the language. In this context Nepali kin terms will be used like any other lexical item; but the important difference is that they are used in what people are themselves aware of as a Gurung context.

One of the clearest examples of how this context can differ is in the area of reference to one's children's generation. Gurung and Brahmin-Chetri

terminological systems agree in having different terms for use by male and by female Ego in this area. In each case, the children of brothers and male parallel cousins only are classified with own "son" and "daughter" for a man; the children of sisters and of female parallel cousins only are classed with own "son" and "daughter" for a woman. In the Brahmin-Chetri system in the woman's case there is a special term for the children of her brothers: bhadā (male) and bhadai (female). The important differences in the application of this terminological split show up in reference to the children of one's spouse's brothers and sisters. In the Brahmin-Chetri system, Ego calls these children whatever his spouse would call them: thus, for a man, the children of his wife's sisters are "son" and "daughter" while the children of her brothers are bhadā and bhadai. For a woman the children of her husband's brothers are "son" and "daughter" while his sister's children are bhānjā and bhānji. In the Gurung system the situation is exactly opposite. HuSi child can never be bhānjā / bhānji; HuSi will marry a man Ego calls "brother", and her children will be called by the terms for brother's children. WiBro children similarly cannot be bhadā / bhadai for a Gurung man; they are the children of his "sister" and must be called bhānjā / bhānji.

In its application the Gurung terminology assumes a system of reciprocity in marriage. In the Brahmin-Chetri system, as I have explained more fully in my article on this subject, there is rarely if ever any reciprocal relationship set up by marriage but rather a spreading system of unequal status contracts. The terms bhānjā and bhānji for a Brahmin-Chetri refer to children with whom he has a prescribed relation of "love", but there is tension outside this relationship since these are children of a lineage to which one's own lineage has provided a wife. In the Brahmin-Chetri system, māmā must defer to bhānjā.

The opposite is true for Gurungs. The MoBro, ā syō, is of a lineage which has provided a wife to the lineage of his sister's son. Although there is a relation of love here for both brahmin-Chetris and Gurungs, the Gurung system expresses a different status relationship: bhānjā must bow to ā syō when formal greetings are exchanged. For the Brahmin-Chetris, a wife given is lost and brings no return. For the Gurungs, a daughter is expected to return to her mother's birthplace.

CONCLUSION

In the first section of this article the circumstances and patterns of Gurung adaptation to city life in the rapidly-modernizing Pokhara area were discussed. Patterns of social organization show a definite nature in these circumstances: preference for grouped settlement rather than for life as a single family separated from one's neighbors; preference for cooperative endeavor and egalitarian relations; and so on. It was shown that these patterns also appear schematically in the Gurung kinship and marriage systems. Kinship and marriage are shown to be important in that the principles on which they are organized are important in other areas of social life, and in that these principles promote change along particular adaptational lines. Even when the persons involved in a new endeavor are not one's own kin, a shared system of this sort will make the organization of new systems and even the choice of endeavor easier. For example, age-grading has been discussed, and the Gurungs' ready adaptation to army life both in the past and present seems founded on this social organizational principle.

Tradition in social organization exists only in retrospect. Change is always going on, and cultural principles guide the process of selection and

adaptation. We must look for such selective and organizing principles when we seek to understand the actual basis of a particular culture within a wider civilization and economic setting.

NOTES

1 See Pignède 1966 for a study of their village life.

2 In an earlier article I dealt with kin and marriage patterns and economic change with reference to the Brahmin-Chetri inhabitants of the Pokhara area. See Doherty 1974 (in press).

3 These areas lie primarily but not completely in the following west central districts, which focus on Pokhara as a city center: Kaski, Parbat, Syangja, and Lamjung.

4 The phrase in Nepali is dhikuti khelnu, "to play dhikuti".

5 Pignède also noted these traits and treated their action in village life in some detail, although he did not attempt to relate them to other specific aspects of Gurung culture.

6 Pignède also uses "clan" for jāt in this context. Clan membership is important for Gurungs and is more valuable socially to them than, for example, Brahmin-Chetris' common membership in a segmentary lineage or thar.

7 In the sections on kinship I have used terms from both the Lamjung District border (EGrg) and Parbat District (WGrg) dialectal areas. Where there is appreciable difference on any given form I have noted the source used. The terms are given as I have transcribed them myself in the field. The transcription used is essentially that of Turner for the Nepali language, with the addition of h for an aspiration which assumes the character of a high tone in syllable-final position.

8 Thakali informants agree that either father's sister's or mother's brother's child is an acceptable marriage partner. They say that the MoBroDa is "somewhat" preferred. There also seems to be very heavy stress laid by Thakalis themselves on the desirability and the desirable social consequences of sister-exchange marriage; this form of marriage, with no obligation to repeat it over several generations between the same two lineages, may be the most-preferred system for the Thakalis.

As yet I have no firm marriage-rule information for the Manang-gis.

9 I have used the Nepali terms for these clans as they are the ones most commonly used in Pokhara and are often used in a village context also. Gurung terms from Parbat District and from other areas, for both the Four Clans and the Sixteen Clans, are given and discussed in Pignède, chap. V.

10 Pignède (see chap. V. for his full discussion) relates the Ghale-Ghotane, Lāmā-Lāmchāne dājū-bhāi relationship to contact with Brahminical norms. Etymologically he relates Ghale and Ghotane as clan names to the civil authority of ancient Gurung society, and Lāmā to the religious authority. Through contact with Hinduism, he says, Gurungs came to see these groups as "related" in the same way Chetris are related to all other Chetris and Brahmins to Brahmins in the context of the Hindu varna system.

For two reasons, however, it seems to me that we cannot accept Pignède's conclusions on this point. Most importantly if one is looking for a supposed adoption of the varna system, the consequences would be endogamy and not exogamy for the "civil authority" and "religious authority" groups. Secondly, Pignède is unable to relate Lāmchāne as a name to any etymology from the religious sphere. It is an adopted Brahmin-Chetri name, as he notes: the name for one of the many Brahmin-Chetri thars. Pignède gives the Gurung term which is plon; but he traces it to Tibetan blon or "local councilor", "nobleman". Moreover the Ghale clan's traditional priests, as Pignède notes and as my informants state, are the Ghyābre who belong to the Sixteen Clans.

It seems to me that the simplest and most logical conclusions to draw concerning the Four Clan/Sixteen Clan division, and the special inter-clan marriage arrangements practiced by Four Clan people in some areas, are those which I have drawn above. In the origin legends Pignède collected (1966: chap. V) and in those I have heard the only real distinction we can draw is that drawn by the Gurungs themselves at the present day, who say that traditionally the village headmen were taken from the Four Clan group. Most probably various clans of both Four and Sixteen status (as they are now designated) arrived at different times. Under conditions of pressure from Brahmin-Chetri immigration or simply as a local arrangement, some powerful clans may have formed ritual brotherhood relations. There are indications that there was also consolidation which occurred fairly recently; as the Lamchane clan, according to Pignède and as my own data suggest, is actually a group of named sub-clans. These arrangements of alliance and consolidation if they occurred could have resulted in the special marriage customs discussed above. But these marriage arrangements, as well as the social division suggested by the terms cārjāt and sorajāt, would have to be considered as of ad hoc origin and not as part of the most ancient Gurung heritage.

11 In the Gurung reckoning of the cycle New Year's comes on the 15th of the Nepali month Push, thus falling in late December. A year of age in the cycle is reckoned according to the number of new years begun since one was born; thus a child can be born in early December and be reckoned a year old according to the cycle by the following January, a matter of only a few weeks.

Age terms are often used as ordinary names and except for "eldest" and "youngest" are usually those taken from Nepali. The Nepali system is given in detail in Doherty 1974: note 4.

BIBLIOGRAPHY

- Doherty, Victor S. The organizing principles of Brahmin-Chettri kinship.
1974 In Contributions to Nepal Studies: vol. I , no. 2
Kathmandu: Tribhuvan University Institute of Nepal and Asian
Studies.
- Fox, Robin. Kinship and Marriage. Baltimore: Penguin Books.
1967
- Hitchcock, John T. The Magars of Banyan Hill. New York: Holt, Rinehart
1966 and Winston.
- Messerschmidt, Don. Rotating credit in Gurung society: the dhikur associa-
1972 tions of Tin Gaun. The Himalayan Review: vol. V, no. 4. Kathmandu.
- Pignede, Bernard. Les Gurungs. The Hague: Mouton.
1966